

## NELES MAPABLOC, BM SERIES BUTTERFLY VALVE WITH DOUBLE BLOCK AND BLEED SEALING SYSTEM

Metso's Neles Mapabloc butterfly valve has been especially designed for use in temperatures, ranging from -200 °C up to 1000 °C. The double block and bleed sealing system gives the valve a safe, extra tight seal.

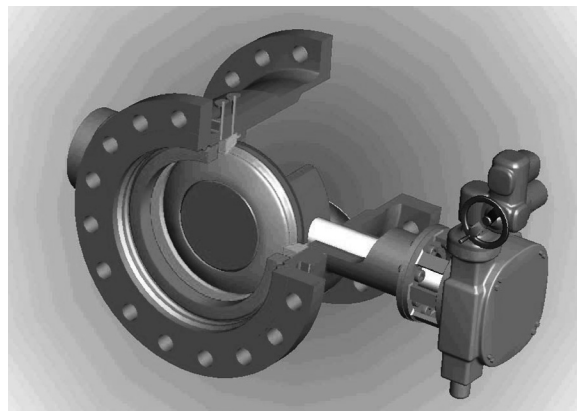

### Valve end connections

The valve is available as flanged, wafer, wafer-lug or with butt weld ends.

### Shaft and drive shaft design

The Series BM butterfly valve has a two piece shaft design which gives a high flow coefficient. Both shafts have two pairs of bearings. The axial bearings ensure the correct alignment of the disc. The bearings are made of ceramic coating, which eliminates galling and pickup. High safety factor has been included to bearing design.

The gland packing is live-loaded to ensure minimum emissions and it's located after the outer bearing. The shaft to disc connection exceeds the strength of the top of the shaft. Overload will result in the failure of the external part of the shaft.

### Sealing element

The two metal sealing elements are located on the disc edge. Tight, reliable seal is ensured by using materials with similar thermal expansion for both disc and sealings. The surface of the sealing elements are hard coated giving excellent resistance to wear and erosion.

When the valve closed, the drain hole in the body is positioned between the two sealing elements with the two functions: firstly to check for leakage from the valve in the closed position and secondly the hole can also be used to add additional sealing fluid if required. The Mapabloc butterfly valve is of a fire safe design from both sides.

### ISO 5211 mounting face

Mapabloc butterfly valve can be assembled with following type of actuators:

- manual gear actuator
- electric actuator
- pneumatic actuator
- hydraulic actuator

Optionally BM series valve can be supplied with any additional control equipment such as a solenoid valve, limit switch or positioner.

### Applications

The butterfly valve is suitable for the following industries and applications.

Industry	Application
Chemical	Process, tail gas, waste water Fluegas, styrene, acrylic acid
Refinery	Flammable media, process, gas
Off-shore	Flammable media, process, gas
Steel	Gas and crude gas
Gas	Natural gas, sour gas
Nuclear power	Steam, gas, water
Conventional power	Steam, gas, water

### Special features

Neles can also offer turn-key solutions for difficult problems such as:

- Valve with heating jacket
- Fire safe design
- Design which allows for the flashing and purging of the sealing elements and bearings.
- Sealing for bearings
- Live-loading with seal gas connection
- Quick shut-down valve for safety applications.

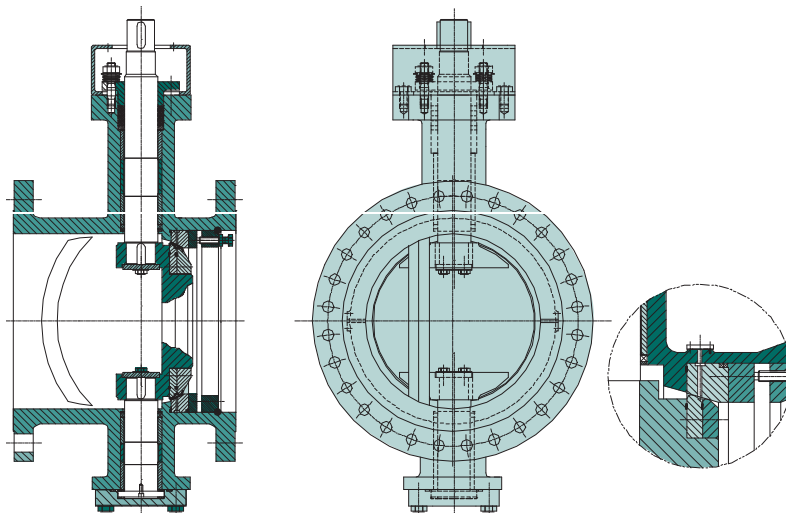

Fig 1. Assembly drawing of the double block and bleed butterfly valve, MAPABLOC.

## Neles butterfly valve, series BM (MAPABLOC)

1.	2.	3.	4.	5.	6.	7.	8.	9.	10.	11.	12.	/	13.	14.
	BM	3	G/D	1	A	56	A	A	C	A	G			

1. sign	
-	

2. sign	PRODUCT SERIES / DESIGN
BM	Double block and bleed valve, double excentric available as Double flanged, Lug, Wafer or But weld end type, metal seated, 4 bearings, two piece shaft

3. sign	BODY CONSTRUCTION
3	Flanged
Y	Special, to be specified

4. sign Body	BODY PRESSURE RATING	4. sign Trim	TRIM PRESSURE RATING Use trim rating e.g. /C if not full rated
C	ASME class 150	/C	dp max 10 bar
D	ASME class 300	/C	dp max 10 bar
J	PN10	/J	PN10
K	PN16	/J	PN10
L	PN25	/J	PN10
M	PN40	/J	PN10

e.g. BW1D/C... --> full rated body #300, de-rated trim #150

5. sign	SEAT DESIGN
4	Double sealing on disc + additional sealing ring Only type BM (MAPABLOC)
Y	Special construction

6. sign	BEARING AND BODY DESIGN
B	4 bearings GGG-CrNi + ceramic coating on shaft bearing surface or eq Not NACE
BN	4 bearings GGG-CrNi Ni resist+ceramic coating 400 or eq bolting/bearing/clamp ring materials acc to NACE
Y	Special construction

7. sign	SIZE (ASME rating = inches / PN rating = mm)
BM	Inch: 12, 14, 16, 18, 20, 24, 28, 30, 32, 36, 38, 40, 42, 48, 52, 54, 56, 60, 64, 72 Metric: 300, 350, 400, 450, 500, 600, 700, 800, 900, 1000, 1200, 1400, 1500, 1600

NOTE: Check the recommend material combination from the Factory.

MATERIAL CODES					
Standard materials					
8. sign	BODY	9. sign	DISC	10. sign	SHAFT & PINS
P	ASTM A216 WCB / 1.0619 (Casting, mainly for sizes 30" - 48") type BM (MAPABLOC) (Tmax = 400 C)	N2	ASTM A487 CA6NM or SS 410 or 1.4317	N3	SS 420 or 1.4021
Optional materials					
	1.5415 equals ASTM A182 Gr F1 / A204 Gr A (Tmax = 400 C, plate, welded construction)	G5	1.4931	K1	1.4923
	1.7335 equals ASTM A182 Gr F11/ ASTM A387 Gr F11 (Tmax = 538 C, plate, welded construction)			C1	ASTM A638 660 or 1.4980

11. sign	SEAT MATERIAL
S	Stellite/stellited sealing attached on disk + stellite/stellited sealing surface
Y	Special, to be specified

12. sign	PACKING CONSTRUCTION
G	Live loaded graphite packing Firesafe
Y	Special, to be specified

13. sign	SURFACE FINISH FOR JOINTING FACE
-	Ra 3.2 - 6.3, standard, without sign cover: EN 1092-1 Type B1 (Ra 3.2 - 12.5) ASME B16.5, Ra 3.2 - 6.3 (125 - 250 µin) DIN 2526 Form E (Ra 4)

14. sign	FLANGE in marked flanges always check suitability from factory
-	without sign according to valve body pressure rating <u>PN-rating</u> EN1092-1 <u>ASME-rating</u> - ASME B 16.5 #150-#300 size 4 - 24, - ASME B 16.47 Series A #150 - 300 size 26" - 60" Bigger flange drilling has to be agreed with the factory. - Butt weld ends acc. ASME B16.25
B	ASME 16.47 Series B (size 26" and bigger), pls consult factory for suitability
J	PN 10
K	PN 16
L	PN 25
R10	JIS 10K (14 bar)
R16	JIS 16K (27 bar)
R20	JIS 20K (34 bar)
Y	Special, to be specified

Subject to change without prior notice.

**Metso Flow Control Inc.**

**Europe**, Vanha Porvoontie 229, P.O. Box 304, FI-01301 VANTAA, Finland.

Tel. +358 20 483 150. Fax +358 20 483 151

**North America**, 44 Bowditch Drive, P.O. Box 8044, Shrewsbury, MA 01545, USA.

Tel. +1 508 852 0200. Fax +1 508 852 8172

**South America**, Av. Independência, 2500- Iporanga, 18087-101, Sorocaba-São Paulo, Brazil.

Tel. +55 15 2102 9700. Fax +55 15 2102 9748/49

**Asia Pacific**, Haw Par Centre #06-01, 180 Clemenceau Avenue, Singapore 239922.

Tel. +65 6511 1011. Fax +65 6250 0830

**China**, 11/F, China Youth Plaza, No.19 North Rd of East 3rd Ring Rd, Chaoyang District, Beijing 100020, China. Tel. +86 10 6566 6600. Fax +86 10 6566 2583.

**Middle East**, Roundabout 8, Unit AB-07, P.O. Box 17175, Jebel Ali Freezone, Dubai, United Arab Emirates. Tel. +971 4 883 6974. Fax +971 4 883 6836

[www.metso.com/valves](http://www.metso.com/valves)

